

# FV Series Nonmetallic Fluorescent Luminaires

## For Hazardous and Adverse Locations

**NEC/CEC:**  
Class I, Division 2, Groups A, B, C, D  
Class II, Division 2, Groups F, G  
Class I, Zone 2, Group IIC

**NEC/CEC:**  
Marine Type Electric Fixture  
Outside Type (Salt Water)  
Type 4X  
Wet Locations

### Applications

- For use in hazardous locations defined by the NEC and CEC as Class I, Division 2, Groups A, B, C and D; Class II, Division 2, Groups F and G; Marine Outdoor Salt Water; UL1598A and Type 4X. As well as hazardous locations defined by the CEC as Class I, Zone 2 II C.
- For use in locations where a high degree of corrosion resistance is required.
- For indoor or outdoor use where protection against dirt, water and moisture is necessary.
- Typical applications include oil refineries, petrochemical facilities, pulp and paper mills, food processing plants, warehouses, underground tunnels and general manufacturing facilities.

### Features

- Stainless steel hubs (3/4") provided as standard.
- Ballast options for nearly all U.S. and foreign voltage and frequency combinations are available.
- Low operating costs provide more lumens per Watt than incandescent fixtures.
- Impact-resistant polycarbonate lens is hinged to allow easy access to lamp compartment.
- Corrosion-resistant fiberglass reinforced polyester housing.
- Actuator allows access to lamps and ballast compartment – no tools required.
- Latch assembly and elastomer type gasket provide positive seal from water ingress.
- Safety switch (supplied as standard) disconnects power to lamps and ballast when lens is open.
- Reflector is hinged for easy single-handed entry to ballast compartment.
- Actuator can be removed for tamper-resistant applications.

### Standard Materials

- Housing: fiberglass reinforced polyester
- Lens: polycarbonate
- Gasket: elastomer
- Hubs: stainless steel
- Lampholders: polycarbonate
- Internal reflector: highly reflective white polycarbonate
- Fixed surface mount: (2) 14-gauge stainless steel
- Adjustable wall mount: (2) copperfree (4/10 of 1% max.) aluminum
- 45° fixed wall mount: (2) 11-gauge (1/8") stainless steel
- Chain ring bolt: set of 2 zinc plated steel (internal diameter .78")

### Options

- Individually fused ballast. Add suffix **-F**.
- Terminal block. Add suffix **-T**.
- Emergency battery pack. Add suffix **-EL**.
- Emergency light capability in moments of power interruption. Luminaire automatically switches to emergency mode, keeping one lamp illuminated for a minimum of 90 minutes. When AC power is restored, battery automatically recharges in 24 hours. Initial light output is 600-700 lumens.



### NEC/CEC Compliances and Certifications

- UL Standard: UL 1598, UL 844, UL 60079-0, UL 60079-15, Marine Listed UL 1598A ①
- UL Listed: E10794
- CSA Standard: C22.2 No. 250, C22.2 No. 137, CAN E60079-0, CAN E60079-15
- cUL Listed: E10794

① Does not apply to fixtures with fusing.

# FV Series Nonmetallic Fluorescent Luminaires

For Hazardous and Adverse Locations

**NEC/CEC:**  
Class I, Division 2, Groups A, B, C, D  
Class II, Division 2, Groups F, G



**NEC/CEC:**  
Marine Type Electric Fixture  
Outside Type (Salt Water)  
Type 4X  
Wet Locations

**CEC:**  
Class I, Zone 2, Group IIC

Order using catalog numbering guide below or select catalog number from tables on following pages.

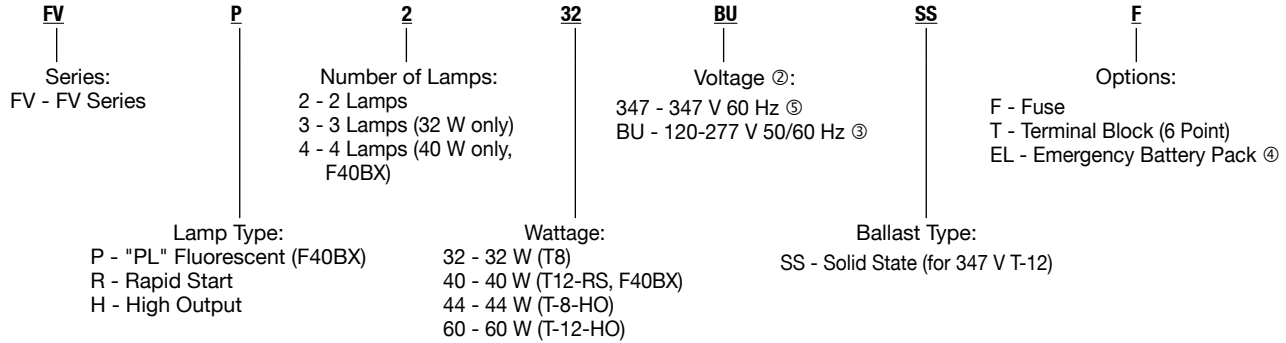
## Catalog Numbering Guide For FV Series Nonmetallic Fluorescent Luminaires



	Number of Lamps	Lamp Watts	Lamp Type	Hub Size (Inches)	Overall Fixture Length Millimeters (Inches)	Volts	Catalog Number
	2	40	F40BX	3/4	787.4 (31)	120-277	<b>FVP240BU</b>
	2	40	F40BX	3/4	787.4 (31)	347	<b>FVP240-347</b> ⑤
	4	40	F40BX	3/4	1397.0 (55)	120-277	<b>FVP440BU</b>
	4	40	F40BX	3/4	1397.0 (55)	347	<b>FVP440-347</b> ⑤
	2	32	T8	3/4	1397.0 (55)	120-277	<b>FVR232BU</b>
	2	32	T8	3/4	1397.0 (55)	347	<b>FVR232-347S0</b> ⑤
	2	44	T8-HO	3/4	1397.0 (55)	120-277	<b>FVH244BU</b>
	2	44	T8-HO	3/4	1397.0 (55)	347	<b>FVH244-347S0</b> ⑤
	2	40	T12	3/4	1397.0 (55)	120-277	<b>FVR240BU</b>
	2	40	T12	3/4	1397.0 (55)	347	<b>FVR240-347SS</b> ⑤
	2	60	T12-HO	3/4	1397.0 (55)	120-277	<b>FVH260BU</b>
	2	60	T12-HO	3/4	1397.0 (55)	347	<b>FVH260-347SS</b> ⑤
	3	32	T8	3/4	1397.0 (55)	120-277	<b>FVR332BU</b>
	3	32	T8	3/4	1397.0 (55)	347	<b>FVR332-347S0</b> ⑤

Note: BU ballasts are auto-sensing, solid state for any voltage between 120 and 277 V, 50 or 60 Hz.

- ① Does not apply to fixtures with fusing.
- ② Consult factory for availability of specific voltages.
- ③ 32 W SS Octron and F40BX only.
- ④ 4' fixture only.
- ⑤ Certified to meet the Canadian Electrical Code (CEC) only.





# FV Series Nonmetallic Fluorescent Luminaires

## For Hazardous and Adverse Locations

**NEC/CEC:**  
Class I, Division 2, Groups A, B, C, D  
Class II, Division 2, Groups F, G

**NEC/CEC:**  
Marine Type Electric Fixture  
Outside Type (Salt Water)  
Type 4X  
Wet Locations

**CEC:**  
Class I, Zone 2, Group IIC

	Description	Standard Materials	Catalog Number
	Surface Mount (set of 2)	14-gauge stainless steel	FVSM
	Adjustable Wall Mount (set of 2)	Copperfree (4/10 of 1% max.) aluminum	FVWAM
	Fixed 45° Wall Mount (set of 2)	11-gauge (1/8") stainless steel	FVWFM
	Chain Mount (set of 2)	Zinc plated steel M8 ring bolts (chain not provided)	FVCM

**Appleton**

FLUORESCENT/AREA: NEC/CEC ENCLOSED AND GASKETED

### Technical Data — Thermal Performance of FV Series Fixtures

For supply connection, use wire rated +75 °C (+167 °F).

Fixture	Quantity	Lamp Watt	Lamp Type	Lamp Lumens	Min. Start Temp °C (°F)	Ambient Temp. °C (°F)	"T" Numbers
FVP240BU	2	40	F40BX	3300	-18 (0)	+40 (+104)	T4
FVP240-347 ②	2	40	F40BX	3300	-18 (0)	+40 (+104)	T4
FVP440BU	4	40	F40BX	3300	-18 (0)	+40 (+104)	T4
FVP440-347 ②	4	40	F40BX	3300	-18 (0)	+40 (+104)	T4
FVR232BU	2	32	T8-RS	2850	-18 (0)	+40 (+104)	T6
FVR232-347S0	2	32	T8-RS	2850	-18 (0)	+40 (+104)	T6
FVH244-BU	2	44	T8-HO	4050	-10 (+14)	+40 (+104)	T6
FVH244-347S0 ②	2	44	T8-HO	4050	-10 (+14)	+40 (+104)	T6
FVR240BU	2	40	T12-RS	3050	-18 (0)	+55 (+131)	T4A
FVR240-347SS ②	2	40	T12-HO	3050	+10 (+50)	+55 (+131)	T4A
FVH260BU	2	60	T12-HO	4050	-28 (-20)	+40 (+104)	T4A
FVH260-347SS ②	2	60	T12-HO	4050	-28 (-20)	+40 (+104)	T4A
FVR332BU	3	32	T8-RS	2850	-18 (0)	+40 (+104)	T6

① Does not apply to fixtures with fusing.

② Certified to meet the Canadian Electrical Code (CEC) only.

# FV Series Nonmetallic Fluorescent Luminaires

For Hazardous and Adverse Locations

**NEC/CEC:**  
Class I, Division 2, Groups A, B, C, D  
Class II, Division 2, Groups F, G

**NEC/CEC:**  
Marine Type Electric Fixture  
Outside Type (Salt Water)  
Type 4X  
Wet Locations

**CEC:**  
Class I, Zone 2, Group IIC

## Dimensions in Millimeters (Inches)

### FV Series

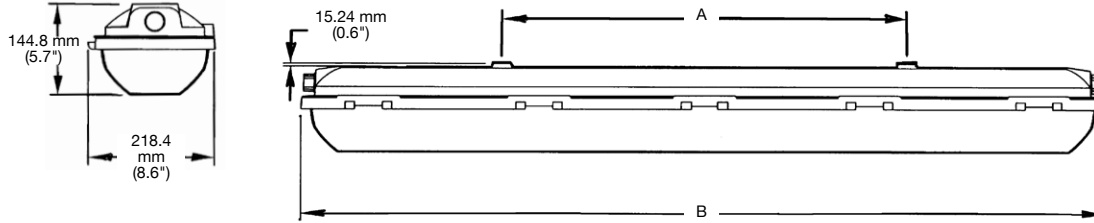

#### FVWFM

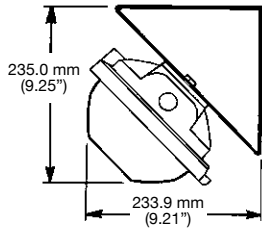

#### FVWAM

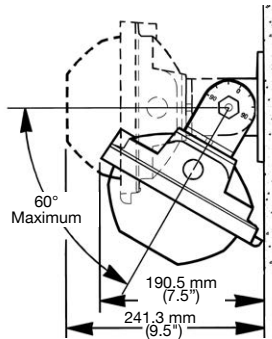

#### FVSM

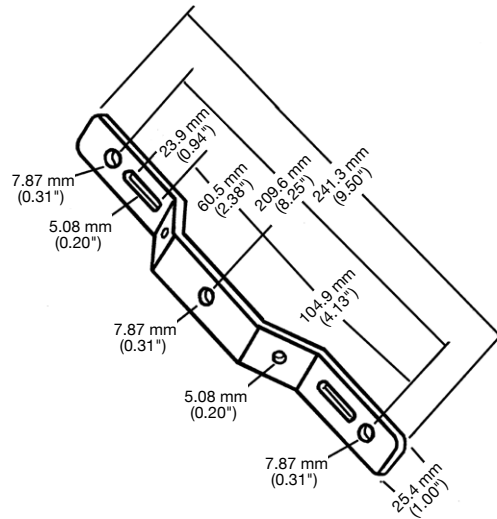

#### FVCM

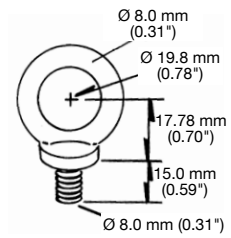

FLUORESCENT/AREA: NEC/CEC ENCLOSED AND GASKETED

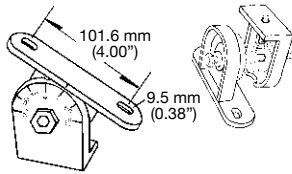
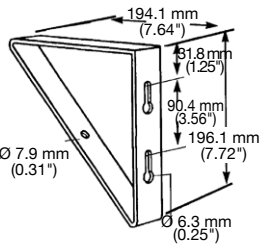

## Mounting Centers and Overall Length in Millimeters (Inches)

	A	B
2 Foot Luminaire	401.3 mm (15.80")	787.4 mm (31.00")
4 Foot Luminaire	701.0 mm (27.60")	1397.0 mm (55.00")

# FV Series Nonmetallic Fluorescent Luminaire Photometric Data

## For Hazardous and Adverse Locations

**NEC/CEC:**  
 Class I, Division 2, Groups A, B, C, D  
 Class II, Division 2, Groups F, G

**NEC/CEC:**  
 Marine Type Electric Fixture  
 Outside Type (Salt Water)  
 Type 4X  
 Wet Locations

**CEC:**  
 Class I, Zone 2, Group IIC

### Photometric Data

CIE TYPE - DIRECT

PLANE: 0 DEG. 90 DEG.

SPACING CRITERIA: 1.2 1.5

CANDELA DISTRIBUTION				
	0.0	45.0	90.0	ZONAL LUMENS
0	1705	1705	1705	
5	1701	1698	1687	161
15	1635	1642	1688	468
25	1513	1581	1660	731
35	1324	1492	1623	932
45	1085	1361	1516	1027
55	806	1161	1292	992
65	490	888	1065	836
75	197	644	821	619
85	32	360	497	351
90	12	257	399	

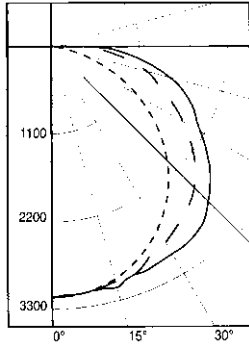

FVP 240, Two 40 W PL Lamps • Total Luminaire Efficiency = 92.7%

% Floors Rfc	% Ceiling Rcc	% Walls Rww	Room Cavity Ratio																			
			80				70				50				30				10			
			70	50	30	10	70	50	30	10	50	30	10	50	30	10	50	30	10	50	30	10
0	1.10	1.10	1.10	1.10	1.08	1.08	1.08	1.08	1.03	1.03	1.03	.99	.99	.99	.95	.95	.95	.93				
1	.99	.93	.89	.84	.96	.91	.87	.83	.87	.83	.80	.83	.80	.78	.80	.78	.75	.73				
2	.89	.80	.73	.67	.86	.78	.72	.66	.75	.69	.64	.72	.67	.63	.69	.65	.61	.59				
3	.80	.69	.61	.54	.78	.68	.60	.54	.65	.58	.53	.62	.57	.52	.60	.55	.51	.49				
4	.73	.61	.52	.45	.71	.60	.51	.44	.57	.50	.44	.55	.49	.44	.53	.48	.43	.41				
5	.67	.54	.45	.39	.65	.53	.45	.38	.51	.44	.38	.49	.43	.37	.47	.42	.37	.35				
6	.62	.49	.40	.33	.60	.48	.39	.33	.46	.38	.33	.44	.38	.33	.43	.37	.32	.30				
7	.57	.44	.35	.29	.55	.43	.35	.29	.42	.34	.29	.40	.34	.29	.39	.33	.28	.26				
8	.53	.40	.32	.26	.52	.39	.31	.26	.38	.31	.25	.37	.30	.25	.36	.30	.25	.23				
9	.50	.37	.29	.23	.48	.36	.28	.23	.35	.28	.23	.34	.27	.23	.33	.27	.23	.21				
10	.46	.34	.26	.21	.45	.33	.26	.21	.32	.25	.21	.31	.25	.21	.30	.24	.20	.19				

CIE TYPE - DIRECT

PLANE: 0 DEG. 90 DEG.

SPACING CRITERIA: 1.2 1.5

CANDELA DISTRIBUTION				
	0.0	45.0	90.0	ZONAL LUMENS
0	3152	3152	3152	
5	3139	3138	3130	299
15	3030	3060	3036	868
25	2798	2910	3041	1351
35	2470	2740	2091	1720
45	2043	2517	2760	1897
55	1523	2130	2373	1827
65	941	1656	1976	1553
75	378	1234	1532	1163
85	49	679	901	649
90	10	474	694	

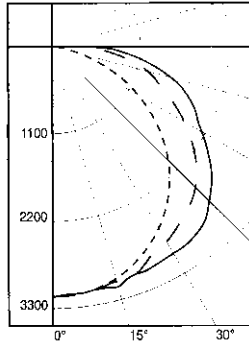

FVP 440, Four 40 W PL Lamps • Total Luminaire Efficiency = 85.8%

% Floors Rfc	% Ceiling Rcc	% Walls Rww	Room Cavity Ratio																			
			80				70				50				30				10			
			70	50	30	10	70	50	30	10	50	30	10	50	30	10	50	30	10	0		
0	1.02	1.02	1.02	1.02	1.00	1.00	1.00	1.00	.95	.95	.95	.91	.91	.91	.88	.88	.88	.86				
1	.99	.93	.89	.84	.96	.91	.87	.83	.87	.83	.80	.83	.80	.78	.80	.78	.75	.73				
2	.89	.80	.73	.67	.86	.78	.72	.66	.75	.69	.64	.72	.67	.63	.69	.65	.61	.59				
3	.74	.64	.56	.50	.72	.63	.56	.50	.60	.54	.49	.58	.52	.48	.55	.51	.47	.45				
4	.68	.56	.48	.42	.66	.55	.48	.42	.53	.46	.41	.51	.45	.40	.49	.44	.40	.38				
5	.62	.50	.42	.36	.60	.49	.41	.35	.47	.40	.35	.46	.39	.35	.44	.39	.44	.32				
6	.57	.45	.37	.31	.55	.44	.36	.31	.42	.36	.30	.41	.35	.30	.40	.34	.30	.28				
7	.53	.41	.33	.27	.51	.40	.32	.27	.38	.32	.27	.37	.31	.26	.36	.30	.26	.24				
8	.49	.37	.29	.24	.48	.36	.29	.24	.35	.28	.24	.34	.28	.24	.33	.27	.23	.22				
9	.46	.34	.26	.21	.45	.33	.26	.21	.32	.26	.21	.31	.25	.21	.30	.25	.21	.19				
10	.43	.31	.24	.19	.42	.31	.24	.19	.30	.23	.19	.29	.23	.19	.28	.23	.19	.175				

CIE TYPE - DIRECT

PLANE: 0 DEG. 90 DEG.

SPACING CRITERIA: 1.2 1.5

CANDELA DISTRIBUTION				
	0.0	45.0	90.0	ZONAL LUMENS
0	1101	1101	1101	
5	1098	1098	1097	104
15	1056	1069	1085	303
25	976	1026	1093	477
35	856	985	1096	616
45	710	928	1075	703
55	528	830	986	709
65	328	681	849	636
75	132	567	757	530
85	14	340	499	332
90	4	252	397	

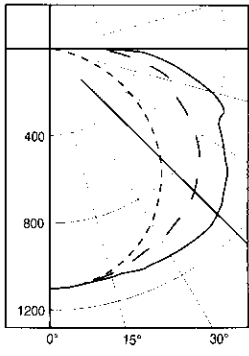

FVR 232, Two T8 32 W Lamps\* • Total Luminaire Efficiency = 77.4%

% Floors Rfc	% Ceiling Rcc	% Walls Rww	Room Cavity Ratio																			
			80				70				50				30				10			
			70	50	30	10	70	50	30	10	50	30	10	50	30	10	50	30	10	0		
0	.92	.92	.92	.92	.90	.90	.90	.90	.86	.86	.86	.82	.82	.82	.79	.79	.79	.77				
1	.81	.77	.72	.68	.79	.75	.71	.67	.71	.68	.65	.68	.66	.63	.65	.63	.61	.59				
2	.73	.65	.59	.53	.71	.64	.58	.53	.61	.56	.51	.58	.54	.50	.56	.52	.49	.47				
3	.65	.56	.49	.44	.63	.55	.49	.43	.53	.47	.43	.51	.46	.42	.49	.45	.41	.39				
4	.60	.49	.42	.36	.58	.48	.41	.35	.46	.40	.35	.44	.39	.34	.42	.38	.34	.32				
5	.55	.44	.37	.31	.53	.43	.36	.31	.41	.35	.31	.40	.34	.30	.38	.34	.30	.28				
6	.50	.39	.31	.26	.49	.38	.31	.26	.35	.30	.26	.35	.30	.25	.34	.29	.25	.23				
7	.47	.35	.28	.23	.45	.35	.28	.23	.33	.27	.22	.32	.26	.22	.31	.26	.22	.20				
8	.43	.32	.25	.20	.42	.31	.25	.20	.30	.24	.20	.29	.24	.20	.28	.23	.19	.18				
9	.40	.29	.22	.18	.39	.29	.22	.18	.28	.22	.18	.27	.21	.18	.26	.21	.17	.16				
10	.38	.27	.20	.16	.37	.26	.20	.16	.26	.20	.16	.25	.20	.16	.24	.19	.16	.14				

CIE TYPE - DIRECT

PLANE: 0 DEG. 90 DEG.

SPACING CRITERIA: 1.2 1.4

CANDELA DISTRIBUTION				
	0.0	45.0	90.0	ZONAL LUMENS
0	1780	1780	1780	169
5	1767	1773	1771	169
15	1700	1732	1757	490
25	1574	1661	1734	767
35	1388	1554	1652	1064
45	1150	1388	1556	1064
55	860	12001	3671	038
65	53	6949	1116	881
75	214	698	914	675
85	21	443	637	426
90	7	319	491	

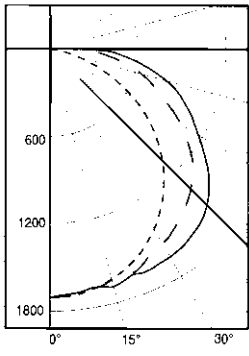

FVR 332, Three T8 32 W Lamps • Total Luminaire Efficiency = 75.7%

% Floors Rfc	% Ceiling Rcc	% Walls Rww	Room Cavity Ratio																			
			80				70				50				30				10			
			70	50	30	10	70	50	30	10	50	30	10	50	30	10	50	30	10	0		
0	.90	.90	.90	.90	.88	.88	.88	.88	.84	.84	.84	.81	.81	.81	.77	.77	.77	.76				
1	.80	.76	.72	.68	.78	.74	.70	.67	.71	.68	.65	.68	.65	.63	.65	.63	.61	.59				
2	.72	.65	.59	.54	.70	.63	.58	.53	.61	.56	.52	.58	.54	.51	.56	.52	.50	.48				
3	.65	.56	.49	.44	.63	.55	.49	.43	.53	.47	.43	.51	.46	.42	.49	.45	.41	.39				
4	.60	.50	.42	.37	.58	.48	.42	.36	.47	.41	.36	.45	.39	.35	.43	.38	.35	.33				
5	.55	.44	.37	.31	.53	.43	.36	.31	.41	.35	.31	.40	.34	.30	.38	.34	.30	.28				
6	.50	.39	.32	.27	.49	.39	.32	.27	.37	.31	.27	.36	.30	.26	.35	.30	.26	.24				
7	.46	.36	.29	.24	.45	.35	.28	.23	.34	.28	.23	.33	.27	.23	.32	.27	.23	.21				
8	.43	.32	.26	.21	.42	.32	.25	.21	.31	.25	.21	.30	.24	.21	.29	.24	.20	.19				
9	.40	.30	.23	.19	.39	.29	.23	.19	.28	.23	.19	.27	.22	.18	.27	.22	.18	.17				
10	.38	.27	.21	.17	.37	.27	.21	.17	.26	.21	.17	.25	.20	.17	.25	.20	.17	.15				